

PEGASUS SELF FIT KIT INSTRUCTIONS - MICRO 10 & 12

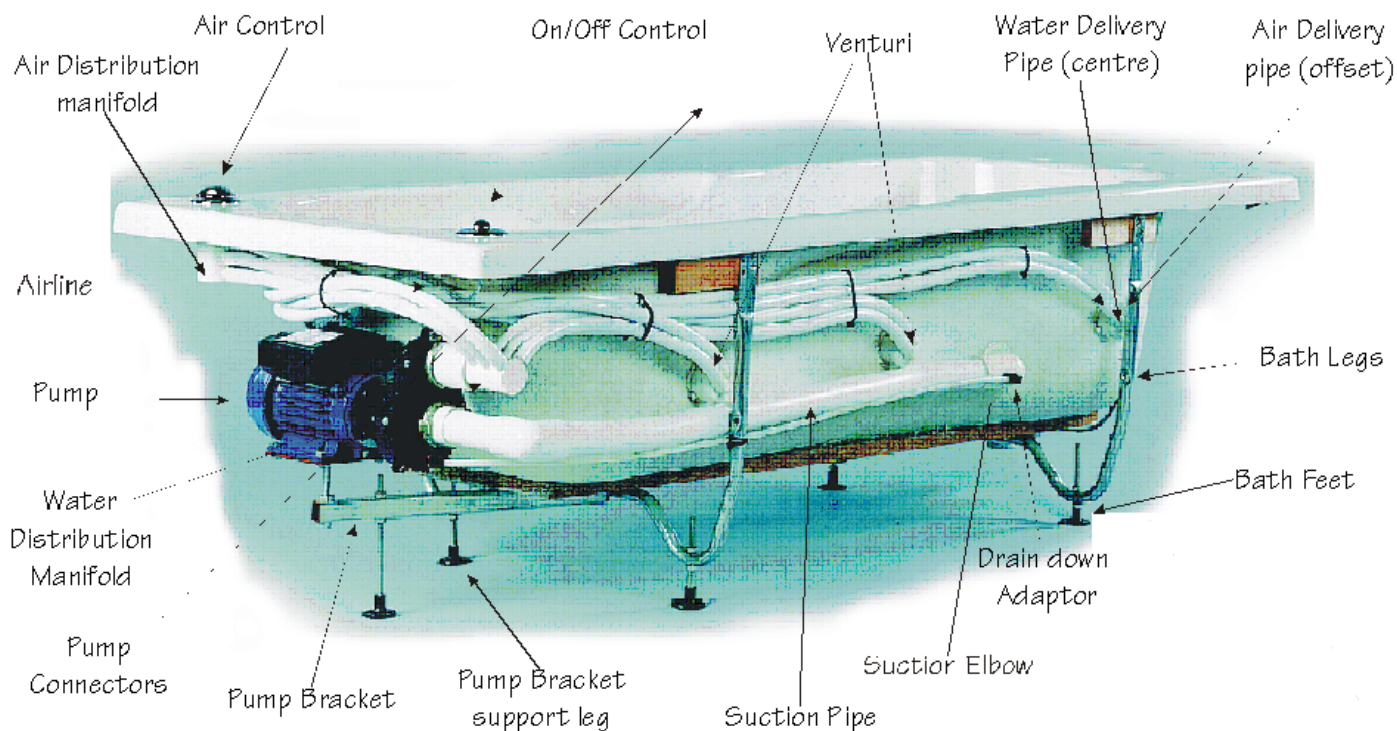

The Pegasus Whirlpool system has been designed to be able to fit to any bath without putting any stress on the bath whatsoever. Jets can be placed to give the customer both aesthetic appeal and maximum hydromassage.

To achieve this jets will usually be located laterally within 1.5" of the desired position, even when up against obstructions such as bath legs - something which can not be achieved with conventional whirlpool systems without placing a lot of stress on the bath or modifying the manufacturers legs.

IMPORTANT NOTES

To ensure that you get the best out of your whirlpool system, please take the time to read these instructions fully before attempting to start to fit the kit.

When gluing pipe to venturi and manifolds be sure that only the exterior surface of the plastics are glued and not the pipework. Take care not to allow glue to get into the interior surfaces or the pipework as this will seriously reduce the performance of the whirlpool system.

When fitting the pump fixing bracket to baseboard of bath be sure to check the length of the screws. The screws supplied are for 3/4" thick encapsulated baseboards.

BASIC FITTING PROCEDURE

1. Check the bath for damage and defects.
2. Fit legs & pump to bath using fixing bracket and screws.
3. Determine position of jets, suction & controls taking care to look for obstructions.
4. Determine the position of the on/off button and air control. Ideally the air control needs to be mounted on a corner of the bath to allow the pipework to be fitted easily.
5. Drill the holes - slowly and carefully.
6. Install all the fittings onto the bath.
7. Connect the pipework between the manifolds and venturi ensuring that all fittings are cleaned with MEK and glue is only applied to the external surfaces of the components - Not to the inside of the pipe or venturi. Ensure pipes are connected to the correct manifolds.

NOTE: When gluing the rigid suction pipe, joints can be glued on both surfaces to ensure adhesion.

8. Watertest the finished product before final installation of the bath.

If you need help fitting this kit please call our hotline before you start.

INSTALLATION SUPPORTLINE

01633 244555

8am - 8pm 7 Days a Week

Our technicians will answer any questions you have about any aspect of fitting this system to your bath.

RECOMMENDED ADHESIVES

Weld on 725 WET 'R' DRY plastic pipe cement.

MEK solvent cleaner.

Dow Corning 785 white silicone sealant.

TOOLS REQUIRED

There is a complimentary pack supplied with this kit that contains almost everything you need including the recommended silicone sealant and PVC cement.

NOTE: If you use the FOC hole saw kit to drill the holes for the jets, you will need to use the 1" holesaw and carefully enlarge the holes with a file to accommodate the jet.

The hole size required is 1 1/16" (27mm)

PEGASUS SELF FIT KIT INSTRUCTIONS - MICRO 10 & 12

DETAILED FITTING INSTRUCTIONS

1. Check the bath for any damage or defects.

- a) Carefully remove the manufacturer's wrapping and any cautionary labels from the bath.
- b) Corners not cracked or broken.
- c) Check that the lip of the bath has been cut cleanly and is not chipped.
- d) Rub the bath over with a dirty, wet duster looking carefully at places where the dust collects in lines. Determine if these lines are scratches which can be easily polished out, or worse, cracks caused by transit damage.
- e) Check that the waste hole is central in the recess.
- f) Check that the tapholes are correct.
- g) Check that the bath is true and not warped.
- h) Check that all the legs and fixing brackets are present - including screws.

2. Fixing the legs and the pump to the bath.

- a) Read through the manufacturer's installation instructions for the bath
- b) Place a dust sheet on a table turn the bath upside down on this sheet and fit the legs and feet to the bath carefully following the manufacturer's instructions. Leave the bath upside down on the sheet and;
- c) Assemble the threaded bar to the Pump Mounting Plate and Pumpstand using the nuts provided.
- d) Assemble the pump to the baseplate using the four nuts and bolts provided.
- e) Glue and assemble the pump outlet manifold which comprises of 3 manifolds, 2 stopends, a 90 degree elbow & a tee. Care should be taken to glue both the male and female parts of all joints to be made. Once the manifold has been glued together fit this and the suction inlet to the pump using the fixing brackets provided.

NOTE: On a 10 jet system you will need to 'loop' out two of the spigots on the water and air manifolds.⁽¹⁾ See pictures.

- f) Offer the pump up to the bath (still-upside-down) and find a position where the pump is central and within the confines of the bath. Be careful to take into account the length of the outlet manifold and any wooden panels which may be subsequently fitted to the bath.

- g) Secure the pump and bracket to the bath using the five screws provided.

IMPORTANT: The screws have been designed to secure the pumpstand to baseboards with a thickness of 3/4" - check the length of the screws against the thickness of the baseboard before attempting to fix the pump stand to the baseboard. A good guide to the thickness of the baseboard is the length of the screws supplied to fix the legs to the bath! - if in doubt use shorter screws. Under no circumstances attempt to fit the Pumpstand to a bath manufactured from GRP - GRP Baths do not have baseboards.⁽²⁾

3. Position the jets, suction and controls.

- a) The number of jets to be fitted and the shape of the bath will usually determine the jet positions.
- b) Jets are normally equally spaced along each side of the bath but can be fitted on any flat surface. 10 and 12 jet systems are usually fitted with back jets and feet jets. These jets can be positioned lower in the bath than the side jets. Back jets are usually positioned as low as possible.
- c) Ensure positions chosen allow sufficient room for the venturi (watch out for bath support legs) and that the venturi will not interfere with the sitting of the pump.
- d) The suction is best fitted toward the foot end of the bath (away from the seat area). *See Fig. 1*
- e) The difference in height between the jets and suction fitting is important to ensure that the maximum amount of water drains from the system after use.

See Fig. 1.

- f) The suction is the lowest fitting in the bath and should be placed as low as possible on a flat surface. *Fig. 2.*

- g) The centre line of the jets should be 55-60 mm. above the centre line of the suction. *See Fig. 1.*

- h) Note that the water level will need to be some 35mm. above the centre line of the jets. Check that the water level will be below the overflow. *See Fig. 1.*

- i) Mark all the positions with a felt-tip pen.

4. Position the height of the pump.

- a) The pump drain must be level with the suction drain. *See Fig. 1.*

NOTE: If you have purchased a special pop-up waste from us the drain will go to the waste so the pump can be mounted lower.

- b) If the pump is too high, it will not prime. Too low and it will not drain when the bath is emptied. Remember that the water hose is to be connected to the water manifold. *See Fig. 1.*

5. Position the controls.

- a) The on/off button and air control should be fitted to the top surface of the bath.

- b) Check that there is enough space underneath the proposed location of the On/Off and Air Control for the backnut and air manifold to seat properly seat on the underside of the bath. Remember that the air hose is to be connected to the manifold. *See Fig. 3.*

IMPORTANT: Always allow for access to the controls, especially the On/Off control.

6. Drill the holes.

- a) Before drilling the holes, re-check all positions, ensure that the bath legs, panel, pump, fixing battens, etc. will not obstruct fittings or indented hose runs.
- b) Using the correct size hole cutter (see page 7), drill the jet holes from the

PEGASUS SELF FIT KIT INSTRUCTIONS - MICRO 10 & 12

inside of the bath,⁽³⁾ taking care to prevent the drill from slipping.

IMPORTANT SAFETY NOTE:

Always point the drill away from the body when drilling holes - never drill towards you body without a body shield.

- c) Back file the holes with a small round handfile to clear any burrs and unevenness left by drilling the hole.
- d) Clean off the excess pen marks and dust using a tissue dampened with meths. Pay particular attention to clean immaculately around the holes as dust may hinder the effectiveness of siliconing the wall fittings to the bath!

7. Install the whirlpool fittings onto the bath.

- a) The clearwater fixing tool and the 8mm allen key are now required to install the fittings to the side of the bath.
- b) Apply a band of silicone sealant around the wall fitting shoulder of the venturi and the wall fitting. *See Fig. 7.* Using the allen key, fit the Venturi to the bath with the pipes at 45 degrees approximately above horizontal pointing towards the pump,

IMPORTANT: Do not overtighten as damage to the venturi could result.

- c) Repeat the above operation for the remaining wall fittings and clean off any excess silicone sealant.

NOTE: The wall fitting with two holes in the face is the suction wall fitting.

8. Install suction elbow and hose.

- a) Place a bead of sealant around the shoulder of the suction wall fitting and the flange of the suction elbow. Using the key from the clearwater fixing tool, assemble the suction fitting. *See Fig. 5.*
- b) Measure and cut to length the suction Pipe and glue to the suction elbow and pump elbow using a recommended adhesive
- c) Clean off any excess sealant.

9. Connect the pipework to the manifolds.

- a) Starting at the jet closest to the pump, measure the length of water and air hose required to connect the Venturi to the water and air manifolds. Glue the hose to the Venturi using a recommended adhesive.

IMPORTANT: Only glue the exterior of the venturi - not inside the pipe!

- b) Hose should be taut but not stretched and with a fall either to Venturi or pump without sagging. *See picture on Page*
- c) Ensure water hose is connected to pump manifold and air hose to air manifold.

10. Fix Drain Line.

- a) Cut the drain line to length.
- b) Fit it to the pump using tubing provided. *See Fig. 6.*
- c) Cut the tube to length and secure the loose end to the suction elbow.

12. Fit the suction cover.

- a) Secure the suction cover to the wall fitting using the two screws provided.

13. Connect on/off button to pump.

- b) Push 3mm bore clear hose onto button and to switch in terminal box.

IMPORTANT: Do not allow pump to run without water in the pump as costly damage may occur.

14. Clean and test.

- a) Ensure all debris is cleared from bath.
- b) Fill with water to a level of three inches above the jets.
- c) Allow to stand for five minutes and then check to ensure that all joints are watertight.
- d) Activate pump and re check all joints.
- e) Leave pump running for 20 minutes.
- f) Turn pump off and continue to fill bath up to the level of the overflow. Leave the bath stand for 30 minutes again.

15. Fit the jet covers.

- a) Push the jet covers onto the venturi.

NOTE: You may need to file the ridges on the spigot if you find them difficult to fit.

16. Connecting to mains supply.

- a) Connection should always be entrusted to a suitably qualified electrician and carried out in accordance with Wiring Regulations.
- b) The pump should be connected into a waterproof junction box the bath, 50mm. above floorboard level to prevent ingress of water should flooding or water leaks occur. *See Fig. 13.*

IMPORTANT: Complete instruction 13 before switching on mains supply.

SUPPLEMENTARY NOTES

(1) When fitting a 10 jet system simply glue a loop of pipe between the two unused branches. *See Picture.* This can be cut off should you wish to upgrade your system to an 12 jet.

(2) Most baths nowadays are moulded from Acrylic which is then back sprayed with chopped strands of GRP. A length of chipboard is then stuck to the base to further increase the strength of the bath. This baseboard may be encapsulated by a further coating of chopped GRP. If in doubt as the material of the bath look carefully in the overflow and you should see a good 3 or 4mm thickness of acrylic with a nominal 2-3mm of acrylic reinforcing. If your not sure ring us before fixing.

(3) Always use a mask when drilling as the dust can irritate throats and may be harmful.

CAUTION: Do not allow silicon sealant to come into contact with the gold plating.

If you have any questions - no matter how small - please call our helpline before you start fitting.

INSTALLATION SUPPORT LINE

01633 244555

8am - 8pm 7 Days a Week

PEGASUS SELF FIT KIT INSTRUCTIONS - MICRO 10 & 12

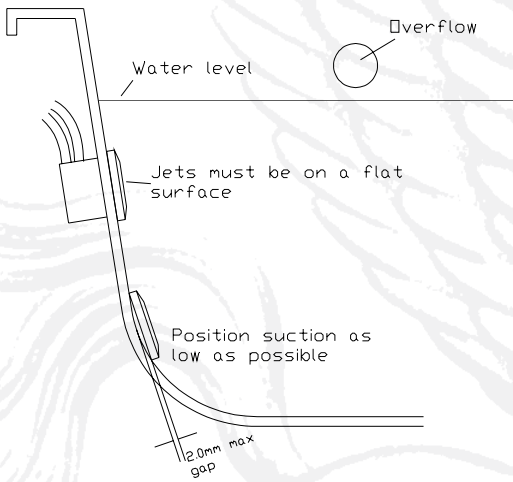
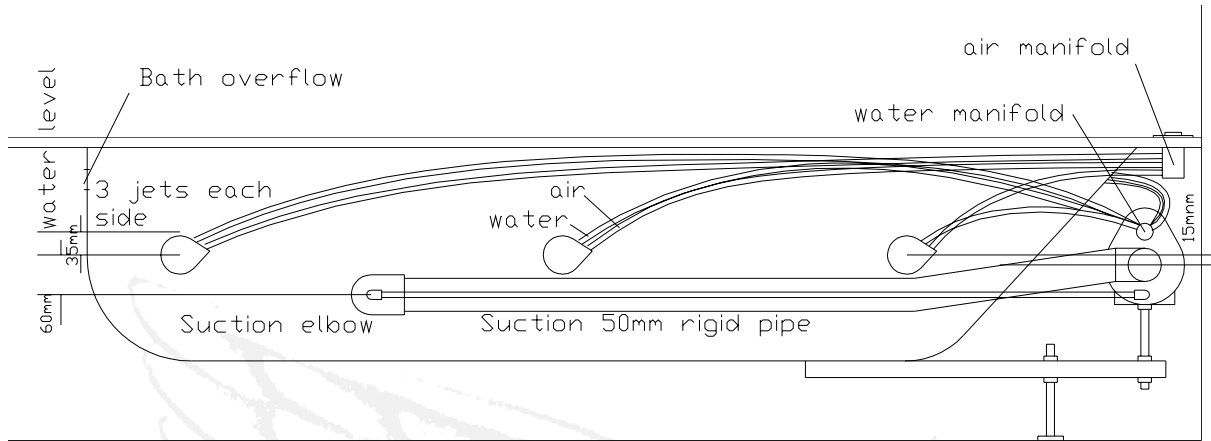

FIG 2

ENSURE MANIFOLD AND BACK NUT WILL SEAT

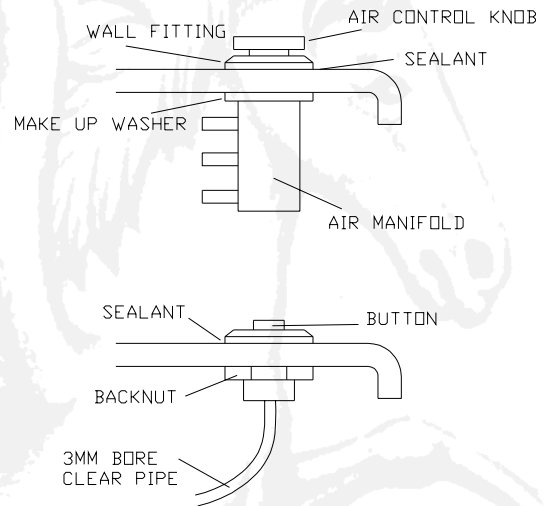
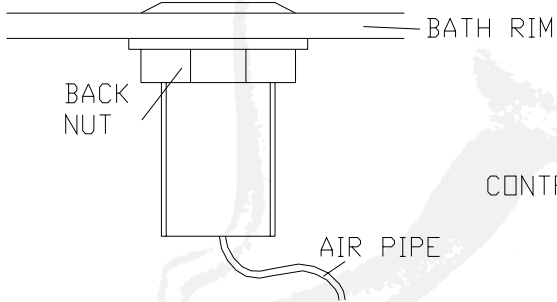

FIG 3



CONTROL BUTTON

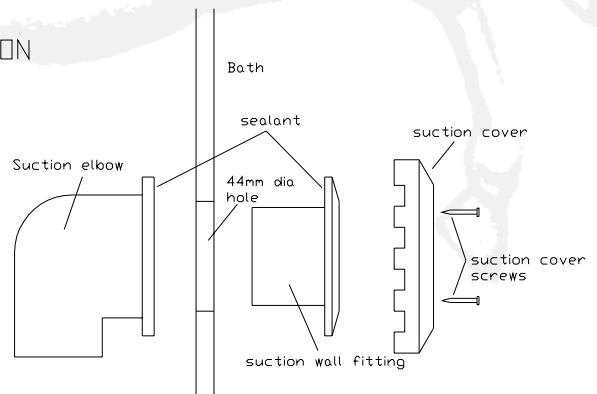

FIG 5

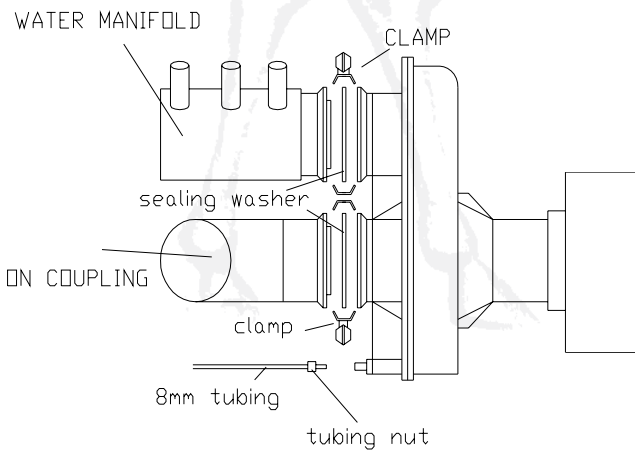

FIG 6

PEGASUS SELF FIT KIT INSTRUCTIONS - MICRO 10 & 12

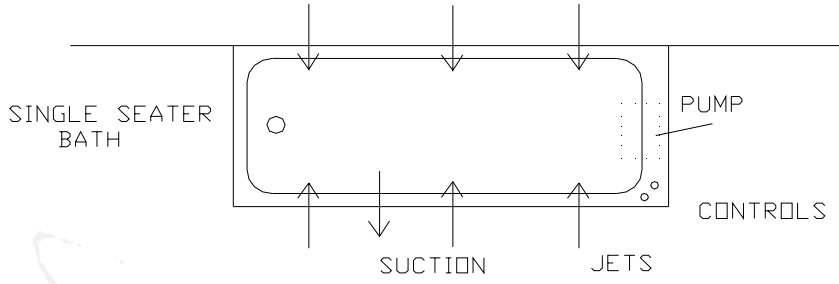

FIG 9

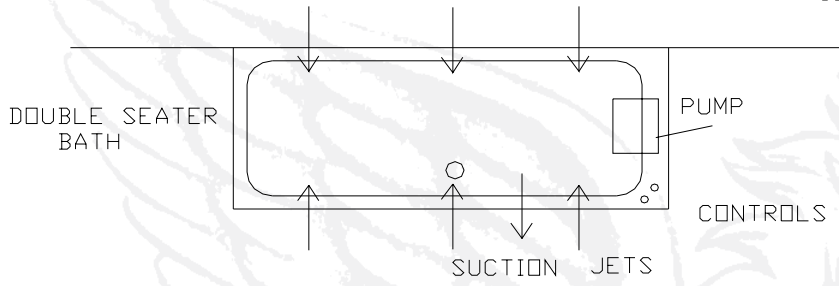

FIG 10

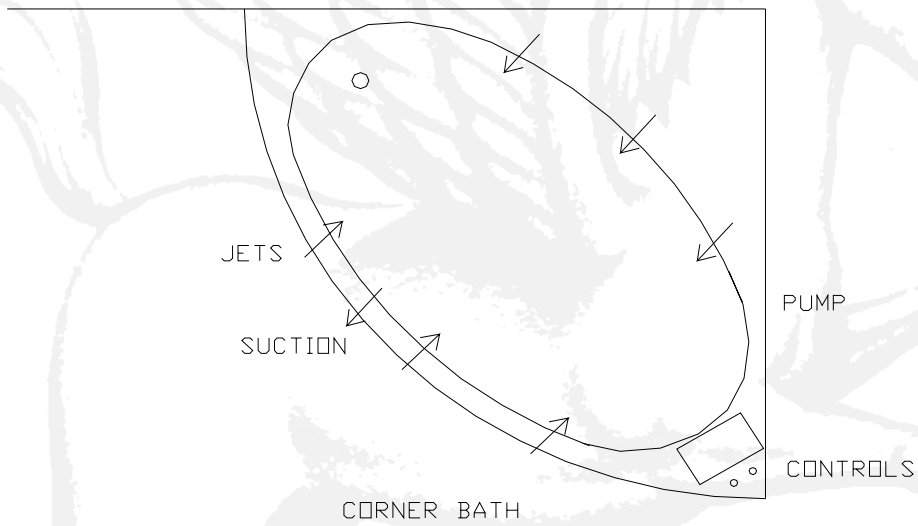

FIG 11

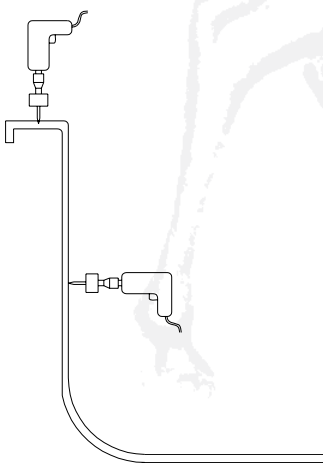

FIG 12

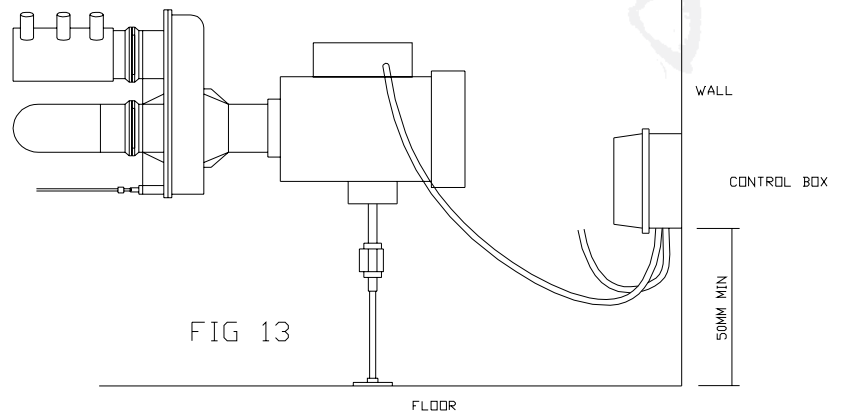
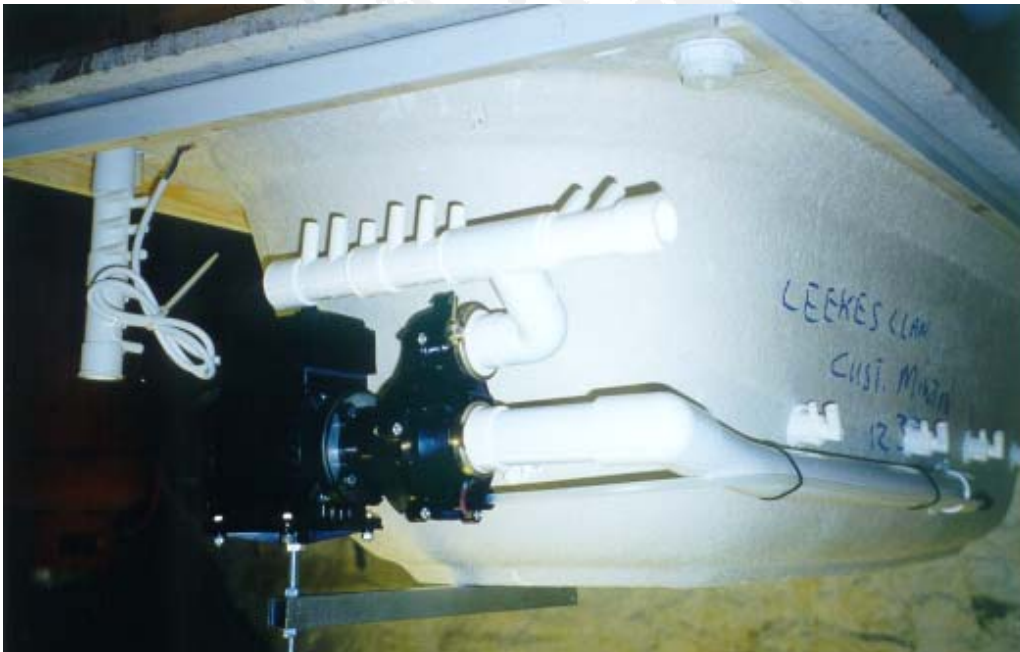

FIG 13

PEGASUS SELF FIT KIT INSTRUCTIONS - MICRO 10 & 12



Above: The finished pipework should look like this - note the constant downward slope and the use of the cable ties



Left: Note the direction of the air and water manifolds

Below right: It is usually easier to push the wall fitting through the bath and screw the venturi on from the back.

Bottom right: Finally, gently tighten the fitting with an allen key.

Bottom Left: Silicone both surfaces of the venturi before fixing to bath.



PEGASUS SELF FIT KIT INSTRUCTIONS - MICRO 10 & 12

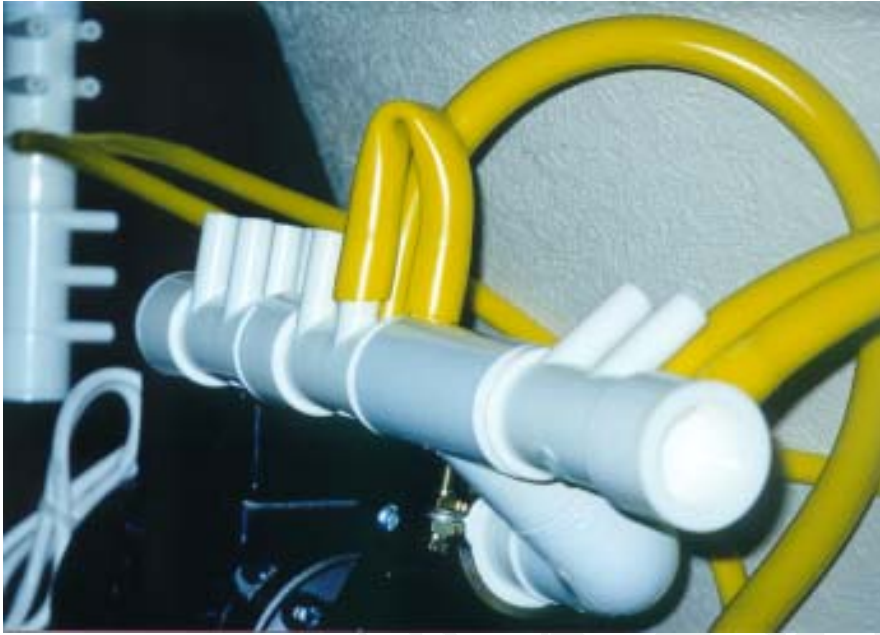

Above: Note the method of blanking

Micro-jet holesaw sizes:

Suction: 1 3/4"

Controls: 1 3/4"

Jets: 1"



Above: Note the bottom two spigots of the air manifold should always feed the back jets to ensure the air manifold drains after use!



Above: Always glue the manifold not the pipe - Take care not to block any spigots with glue - especially when glueing the stop end



Above: The design of the Pegasus system will always allow jets to be placed unobstructed in the back

PEGASUS SELF FIT KIT INSTRUCTIONS - MICRO 10 & 12

PACKING LIST - PEGASUS MICRO 10

K/ASSY/001	SUB PACK, 10 MICROJET VENTURI & WALL FITTINGS	1
K0/3/00	Microjet venturi 12mm water / 8.5mm air	10
K0/3/01	Microjet wall fitting - wall fitting / natural	10
K/ASSY/002	STANDARD AP45 PUMP DELIVERY PACK (MICRO 10/12)	1
K0/13/1-90	1" 90 degree elbow	1
K0/13/1-PVCPIPE	PVC Pipe / 1" / per metre	0.1
K0/13/1-STOPEPEND	Stopend / 1"	2
K0/13/1-TEE	Tee / 1"	1
K0/16/40	Pump profile clamp / AP45	1
K0/16/43	Rubber pump washer 57mmOD x 44.5mmID x 1mm	1
K0/20/2	Manifold, 4-Branch, 12mm OD Multi C type	3
K0/16/41	Pump connector 33mm/1"inch	1
K/ASSY/003	STANDARD PUMP TO SIDEWALL SUCTION PACK	1
K0/12/10	Suction elbow / 1.25" with drain elbow	1
K0/12/21	Wall fitting for suction elbow (drilled)	1
K0/13/1.25-45	Elbow / 1.25" / 45 degree	1
K0/13/1.25-90	Elbow / 1.25" / 90 degree	1
K0/16/40	Pump profile clamp / AP45	1
K0/16/42	Pump coupling flange / ABS / suction / 1.25"	1
K0/16/43	Rubber pump washer 57mm OD x 44.5mm ID x 1mm	1
K/ASSY/004	STANDARD AIR MANIFOLD PACK (MICRO 10/12)	1
K0/13/1-STOPEPEND	Stopend / 1"	1
K0/13/AIRCTLADAPTOR	Adaptor / Multipoint control to manifold	1
K0/20/3	Manifold / 8.5mm OD / AIR / 6 Branch	2
K/ASSY/005	ASSEMBLY - PNEUMATIC SYSTEMS, ACRYLIC BATHS	1
K0/16/01	Pegasus hi-flow pump - 45 GPM	1
K0/16/11	PUMP STAND BAR	1
K0/13/1.25-PVCPIPE	LENGTH OF SUCTION PIPE 1.25"	1
AW/TUBE/80D	METRE 8mm OD NYLON TUBE	1.5
R/CT1816	METRE LENGTH OF 1/8" PNEUMATIC TUBE FOR ON/OFF	1
K/ASSY/006	ASSEMBLY - STANDARD PUMP FIXING	1
K0/16/12	Pump height adjust threaded bar M10 STUD x 150mm ZN	1
K0/16/13	Pump mounting plate	1
K0/16/15	Pump support foot (bath leg) M8 x 180	1
K0/16/24	M6 x 20 Hex bolts for securing pump to stand	4
K0/16/25	M6 nut for fixing pump to pump	4
K0/16/26	M6 plain washer ZN Plated	4
K0/16/27	M6 shake proof washer for pump	4
K0/16/23	M8 nuts for pump support	2
K0/16/28	M10 nuts for pump fixing	4
SC/7605	Quicksilver countersunk woodscrew 1.5" x 8	5
SC/7796	200 mm x 4.5 mm cable ties	12
R/CLT1225M/15/YELLOW	15M ROLL OF CANARY YELLOW 12.5mm TUBE	1
R/CLT815M/15/YELLOW	15M ROLL OF CANARY YELLOW 8mm TUBE	1
K0/.../...	COLOUR SET	1
K0/12/..	Suction cover	1
K0/14/..	Air control	1
K0/17/..	Pneumatic On/off Button	1
K0/03/..	Micro-jet cover - colour as per order	10
FREEBEE/1	COMPLIMENTARY PACK OF CLEANSERS & AROMATHERAPY	1
K/ASSY/007	COMPLIMENTARY PACK OF SELF FIT KIT TOOLS	1
I/725-400	Weld on Wet-R-Dry 725 solvent cement 250ml	1
RO/58129	12 piece holesaw set (.825-2.5inch) including arbours	1
X/BBDM103	Disposable mask set (50 pc)	1
X/BBSG102	Goggles / soft vynil cover / non fogging	1
X/BBTM236	Hi glow power tape measure	1
S/SILICONE/DOW785	Dow corning 785 silicone sealant	1
K/SFKTOOL	Pegasus fitting tool	1
X/BBWR270	Allen key set	1

PEGASUS SELF FIT KIT INSTRUCTIONS - MICRO 10 & 12

PACKING LIST - PEGASUS MICRO 12

K/ASSY/001	SUB PACK, 10 MICROJET VENTURI & WALL FITTINGS	1
K0/3/00	Microjet venturi 12mm water / 8.5mm air	10
K0/3/01	Microjet wall fitting - wall fitting / natural	10
K/ASSY/001A	SUB PACK, 2 MICROJET VENTURI & WALL FITTINGS	1
K0/3/00	Microjet Venturi 12mm Water / 8.5mm Air	2
K0/3/01	Microjet Venturi - Wall fitting / Natural	2
K/ASSY/002	STANDARD AP45 PUMP DELIVERY PACK (MICRO 10/12)	1
K0/13/1-90	1" 90 degree elbow	1
K0/13/1-PVCPPIPE	PVC Pipe / 1" / per metre	0.1
K0/13/1-STOPEPEND	Stopend / 1"	2
K0/13/1-TEE	Tee / 1"	1
K0/16/40	Pump profile clamp / AP45	1
K0/16/43	Rubber pump washer 57mmOD x 44.5mmID x 1mm	1
K0/20/2	Manifold, 4-Branch, 12mm OD Multi C type	3
K0/16/41	Pump connector 33mm/1"inch	1
K/ASSY/003	STANDARD PUMP TO SIDEWALL SUCTION PACK	1
K0/12/10	Suction elbow / 1.25" with drain elbow	1
K0/12/21	Wall fitting for suction elbow (drilled)	1
K0/13/1.25-45	Elbow / 1.25" / 45 degree	1
K0/13/1.25-90	Elbow / 1.25" / 90 degree	1
K0/16/40	Pump profile clamp / AP45	1
K0/16/42	Pump coupling flange / ABS / suction / 1.25"	1
K0/16/43	Rubber pump washer 57mm OD x 44.5mm ID x 1mm	1
K/ASSY/004	STANDARD AIR MANIFOLD PACK (MICRO 10/12)	1
K0/13/1-STOPEPEND	Stopend / 1"	1
K0/13/AIRCTLADAPTOR	Adaptor / Multipoint control to manifold	1
K0/20/3	Manifold / 8.5mm OD / AIR / 6 Branch	2
K/ASSY/005	ASSEMBLY - PNEUMATIC SYSTEMS, ACRYLIC BATHS	1
K0/16/01	Pegasus hi-flow pump - 45 GPM	1
K0/16/11	PUMP STAND BAR	1
K0/13/1.25-PVCPPIPE	LENGTH OF SUCTION PIPE 1.25"	1
AW/TUBE/80D	METRE 8mm OD NYLON TUBE	1.5
R/CT1816	METRE LENGTH OF 1/8" PNEUMATIC TUBE FOR ON/OFF	1
K/ASSY/006	ASSEMBLY - STANDARD PUMP FIXING	1
K0/16/12	Pump height adjust threaded bar M10 STUD x 150m ZN	1
K0/16/13	Pump mounting plate	1
K0/16/15	Pump support foot (bath leg) M8 x 180	1
K0/16/21	Assembly M6 set	1
K0/16/24	M6 x 20 Hex bolts for securing pump to stand	4
K0/16/25	M6 nut for fixing pump to pump	4
K0/16/26	M6 plain washer ZN Plated	4
K0/16/27	M6 shake proof washer for pump	4
K0/16/23	M8 nuts for pump support	2
K0/16/28	M10 nuts for pump fixing	4
SC/7605	Quicksilver countersunk woodscrew 1.5" x 8	5
SC/7796	200 mm x 4.5 mm cable ties	12
R/CLT1225M/15/YELLOW	15M ROLL OF CANARY YELLOW 12.5mm TUBE	1
K0/.../...	COLOUR SET	1
K0/12/..	Suction cover	1
K0/14/..	Air control	1
K0/17/..	Pneumatic On/off Button	1
K0/3/..	Micro-jet cover - colour as per order	12
R/CLT815M/15/YELLOW	15M ROLL OF CANARY YELLOW 8mm TUBE	1
FREBEE/1	COMPLIMENTARY PACK OF CLEANSERS & AROMATHERAPY	1
K/ASSY/007	COMPLIMENTARY PACK OF SELF FIT KIT TOOLS	1
I/725-400	Weld on Wet-R-Dry 725 solvent cement 250ml	1
RO/58129	12 piece holesaw set (.825-2.5inch) including arbours	1
X/BBDM103	Disposabe mask set (50 pc)	1
X/BBSG102	Goggles / soft vynil cover / non fogging	1
X/BBTM236	Hi glow power tape measure	1
S/SILICONE/DOW785	Dow corning 785 silicone sealant	1
K/SFKTOOL	Pegasus fitting tool	1
X/BBWR270	Allen key set	1